

# 1: Wheel dis-assembly shown

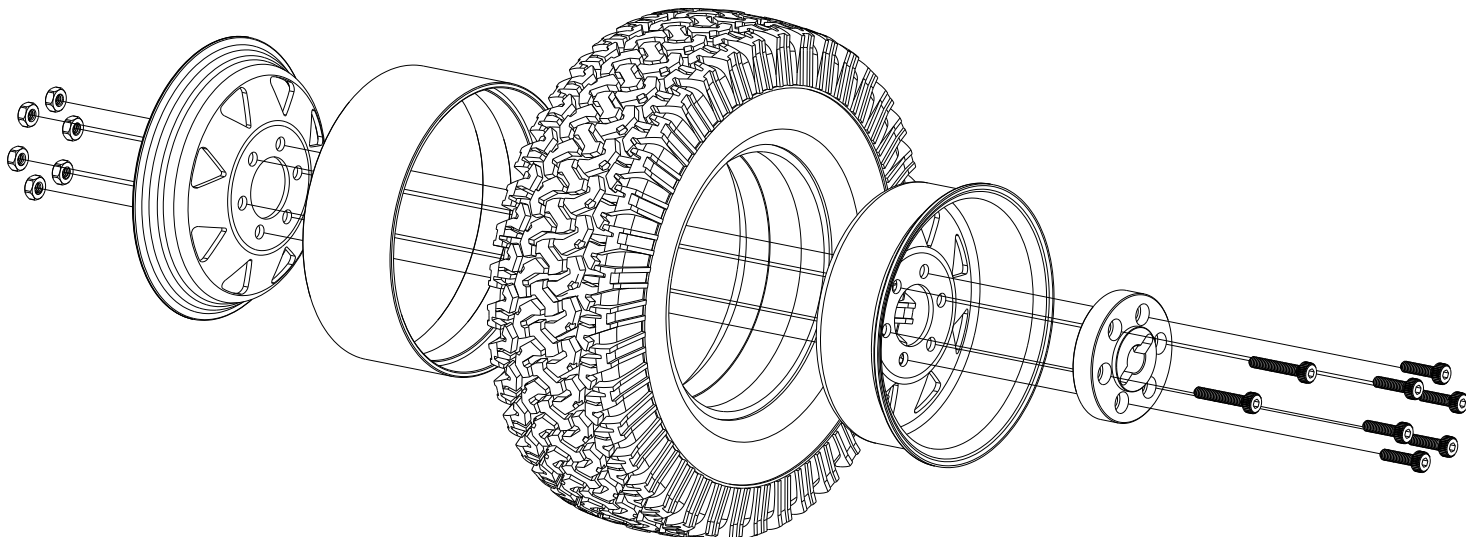

2: Insert internal beadlock ring  
Into tire.

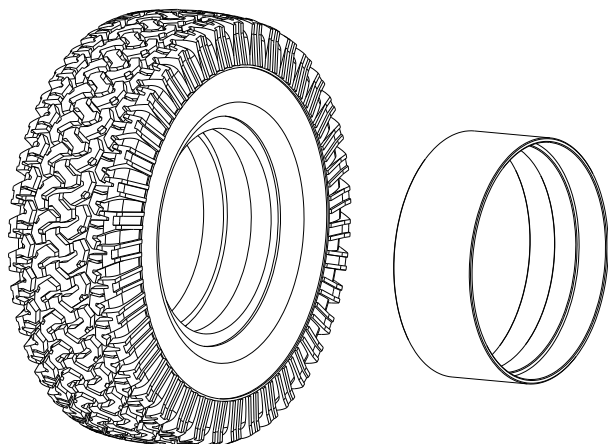

3: Install wheel front and back.  
Careful of the wheels  
alignment to get the correct look.

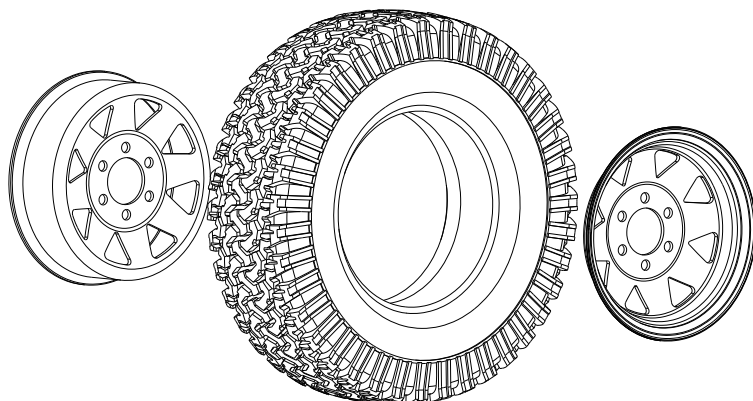

4: Use the included longer hardware  
to help aid in tire and wheel installation.  
Be sure to slowly tighten the nuts on the  
longer hardware until you are able to  
begin installing the include shorter  
hardware.

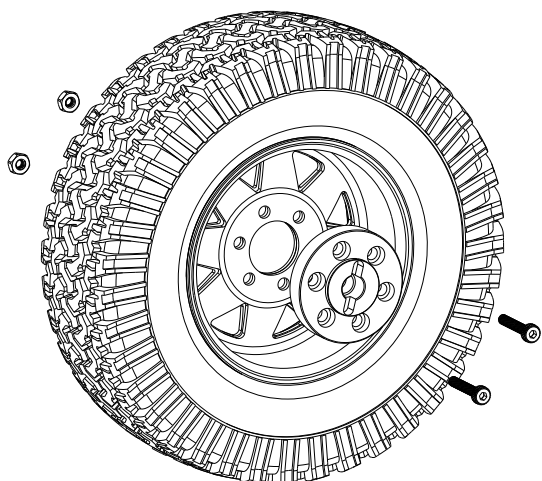

5: Install the correct shorter  
length hardware into the  
remaining holes.

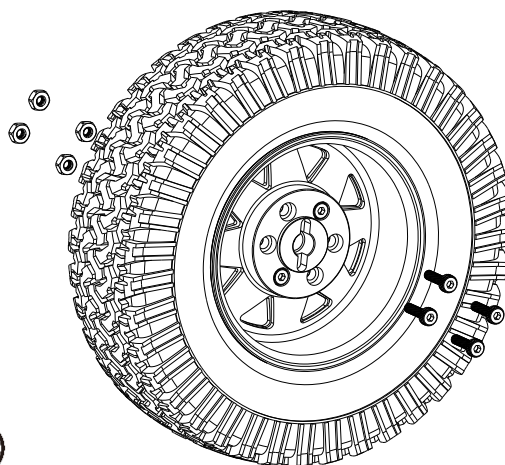

6: Begin to tighten the hardware in a star shape pattern to fully seat the tire to the wheel properly.

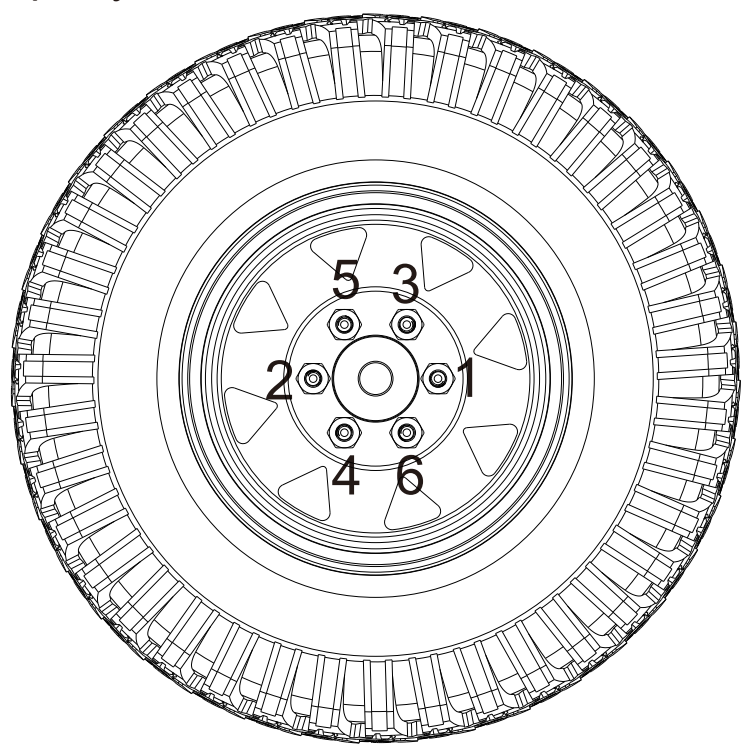

7: Your wheel and tire should be fully seated like shown.

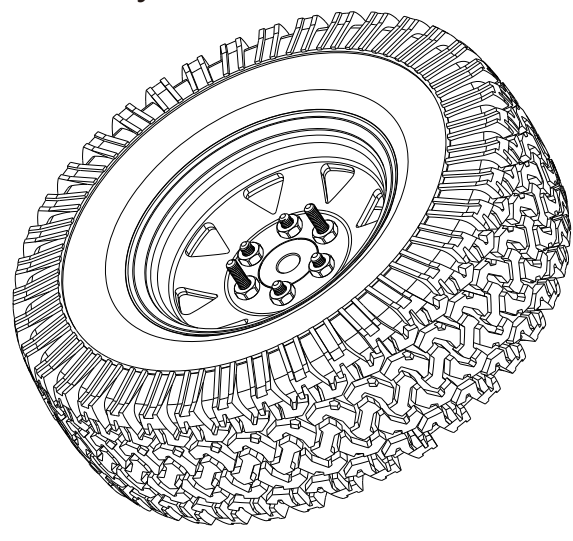

8: Now you can remove the longer hardware.

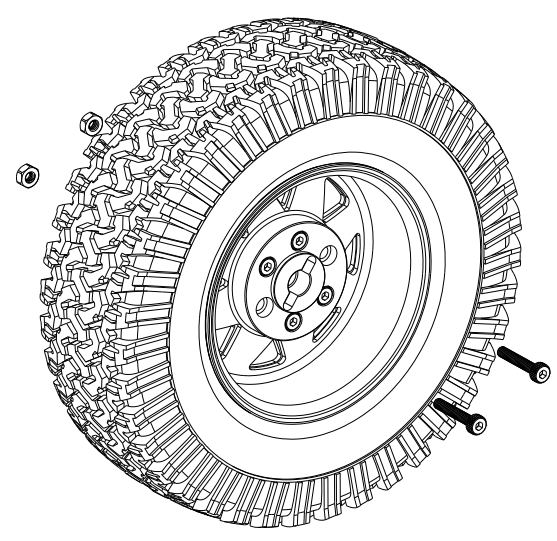

9: Install the correct shorter hardware.

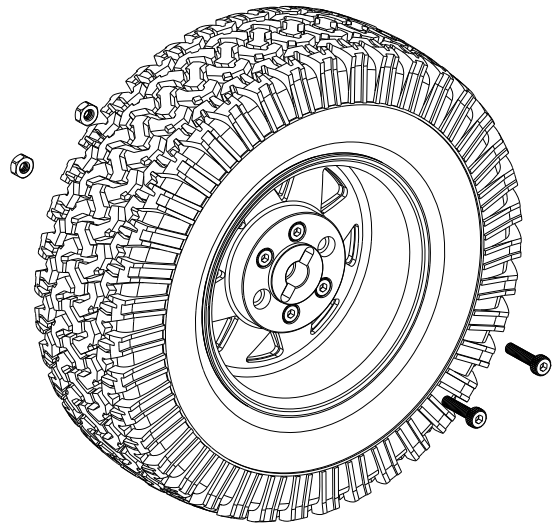

10: Completed assembly of your new wheel and tires.

